

GLASS MELTING BURNER-VM
20 kW & 50 kW (Fuel Gas without valve)

INSTALLATION, ASSEMBLY,
AND MAINTENANCE PROCEDURES



1 - INTRODUCTION	3
2 - DESCRIPTION OF THE GLASS MELTING BURNER-VM	5
3 - INSTALLATION OF THE BURNER	6
3.1 Preparation of the burner parts	6
3.2 Installation of the bracket adapter	6
3.3 Installation of the burner block	7
3.4 Installation of the Oxygen injector and the Fuel Gas injector	7
3.5 Cooling of the burner	8
3.6 Repartition of the Oxygen in the burner	9
3.7 Installation of the burner on the block	10
4 - BURNER MAINTENANCE	11
4.1 Inspection of the injectors	11
4.2 Unmonting the burner	12
4.3 Maintenance	12
5 - SAFETY WITH OXY - COMBUSTION	13
6 - APPENDIX	14
6.1 References	
6.2 Specifications	
6.3 Dimensions	

1 - INTRODUCTION

Glass Melting Burner-VM (Figure 1) is a burner specially developed for glass furnaces. It completes the scale of Glass Melting Burners (tube in tube).

Presently, two ranges of nominal power exist :

Glass Melting Burner-VM 20 (20 kW at nominal power, Gas version).

Glass Melting Burner-VM 50 (50 kw at nominal power, Gas version).

Demonstrated benefits of this burner technology are :

- ◆ To regulate the atmosphere in the furnace.
- ◆ To improve the momentum of the flame (case of boosting).
- ◆ To adjust the flame length according to furnaces geometry (narrow furnaces).
- ◆ To modify the flame luminosity (emission spectrum) according to the type of glass.

This burner is cooling in operation with fluids flowing, like our scale of Glass Melting Burners. An air cooling is only necessary when the burner is stopped.

Glass Melting Burner-VM permits, with an injection of a part of oxygen in the central injector of the burner, to adjust the flame characteristics. It can operate with natural gas or propane.

Its conception permits to operating with a high dynamic (1 to 4), with a minimum of maintenance (monthly inspection).

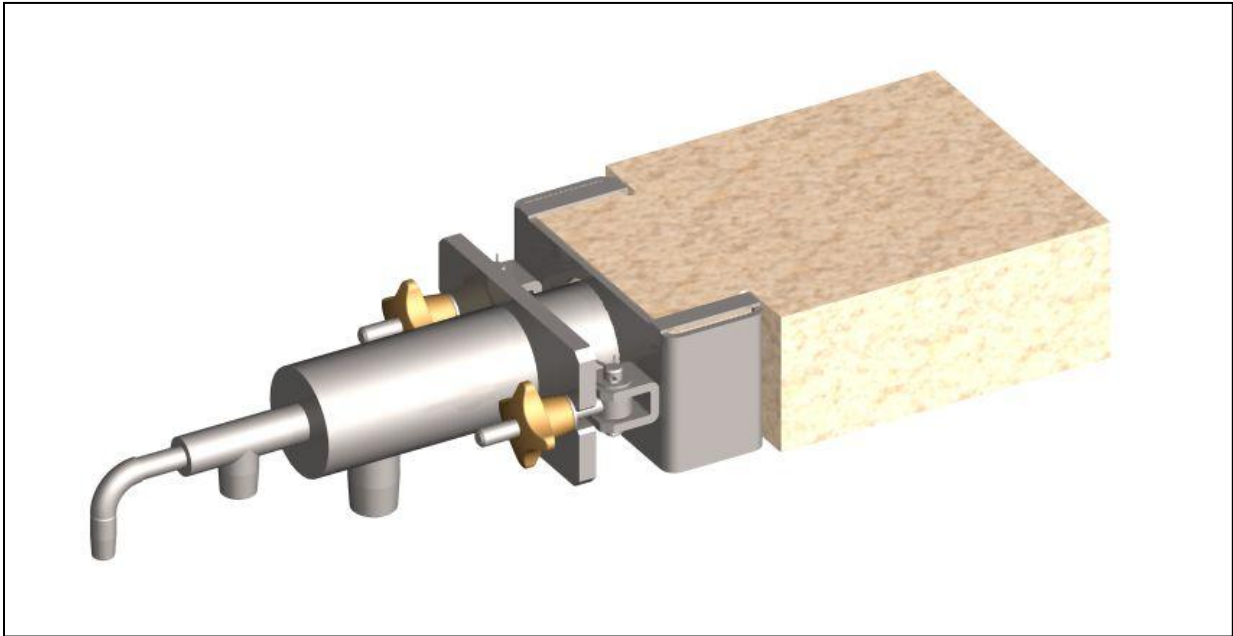

Figure 1

2 - DESCRIPTION OF THE GLASS MELTING BURNER-VM

The Glass Melting Burner-VM is composed of (see figure 2) :

- ◆ The burner block (1) made of refractory material.
- ◆ The bracket adapter (2) in stainless steel for mounting the burner on the block.
- ◆ A ceramic paper gasket (3) to be positioned between the refractory block and the burner.
- ◆ The burner body (4) in stainless steel composed of :
 - The fuel gas lance (5) with a high temperature alloy injector (6).
 - The central oxygen lance (7) with a high temperature alloy injector (8). A « Viton » joint (9) ensures sealing between the fuel gas injector and the oxygen injector.

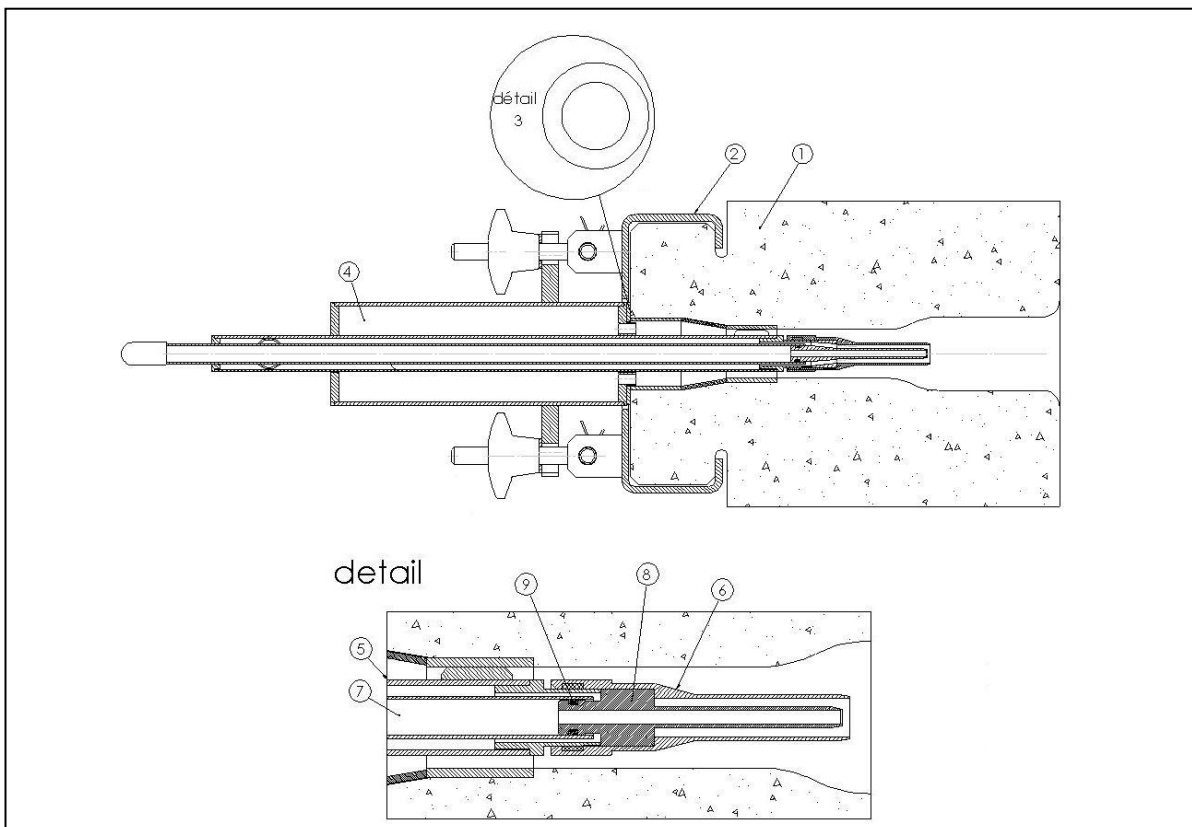

Figure 2

3 - INSTALLATION OF THE BURNER

3.1- PREPARATION OF THE BURNER PARTS

The burner is delivered "oxygen clean". Before assembling the burner, make sure that all parts have not been contaminated by grease, oil or particulates. If it has been contaminated, all metallic parts of the burner must be cleaned one by one in order to eliminate all traces of oil or grease and particulates. Use only oxygen compatible products for this operation.

In case of doubt on what product to use and procedure, contact an Air Liquide representative.

3.2- INSTALLATION OF THE BRACKET ADAPTER

A metallic stop (1) permits to maintain the bracket adapter on the refractory block as described on the figure 3.

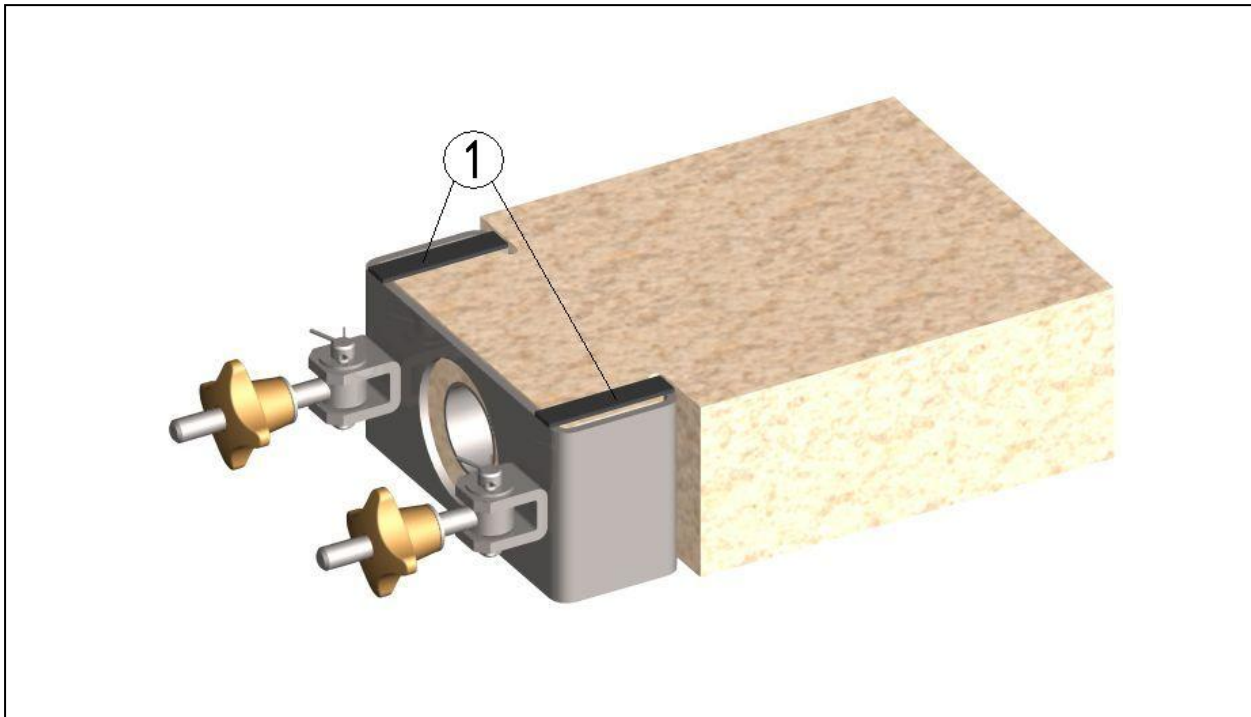

Figure 3

3.3 - INSTALLATION OF THE BURNER BLOCK

Before installing the burner block, check that the support is horizontal or inclined no more than 2° toward the glass surface, to make sure that the flame is not oriented towards the crown of the furnace.

New furnace (cold installation)

- ◆ Place the burner block with its bracket adapter in the dedicated furnace opening.
- ◆ Ensure a proper tightness around the burner block with a heat resistant material.
- ◆ Start the burner as soon as possible.

Existing furnace (hot installation)

- ◆ Preheat the block and its adapter to remove all moisture.
- ◆ Position the block and its adapter in front of the furnace.
- ◆ To avoid thermal shock, push the block with its adapter slowly into the opening, at a rate of 2 inches per hour for the first 6 inches, and 4 inches per hour afterwards (or follow the specific burner block manufacturer instruction).
- ◆ Start the burner as soon as possible.

3.4 - INSTALLATION OF THE OXYGEN INJECTOR AND THE FUEL GAS INJECTOR

- ◆ Insert the oxygen injector (1) in the central oxygen lance (2) as described on the figure 4.
 - **Check that the « Viton » joint (3) is correctly positioned in the injector groove.**
 - **Mounting must be done by hand.**
- ◆ Screw the fuel gas injector (4) on the fuel gas lance (5) as described on the figure 4.
 - **Use a special grease compatible with oxygen.**
 - **Tightening must be done by hand.**
- ◆ Check the centring of the oxygen injector in the fuel gas injector.

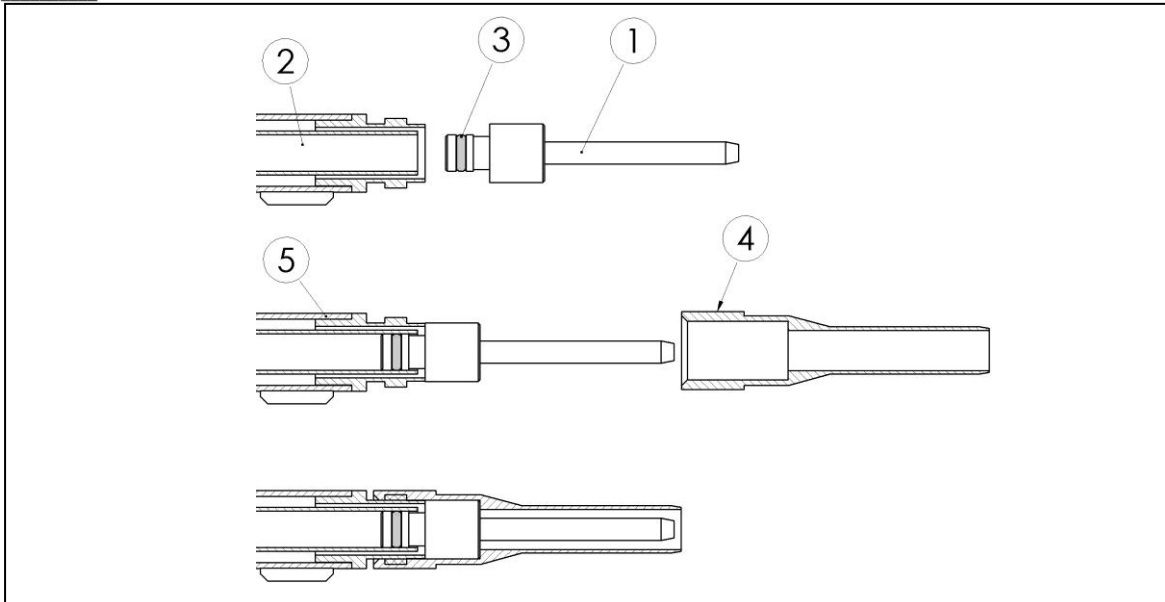

Figure 4

3.5 - COOLING OF THE BURNER

When the burner is turn off, there is immediatly a cooling (nitrogen or oil free dry cooling air) supplied in the principal oxygen hose and in the central oxygen hose to protect the burner and the injectors (see figure 5).

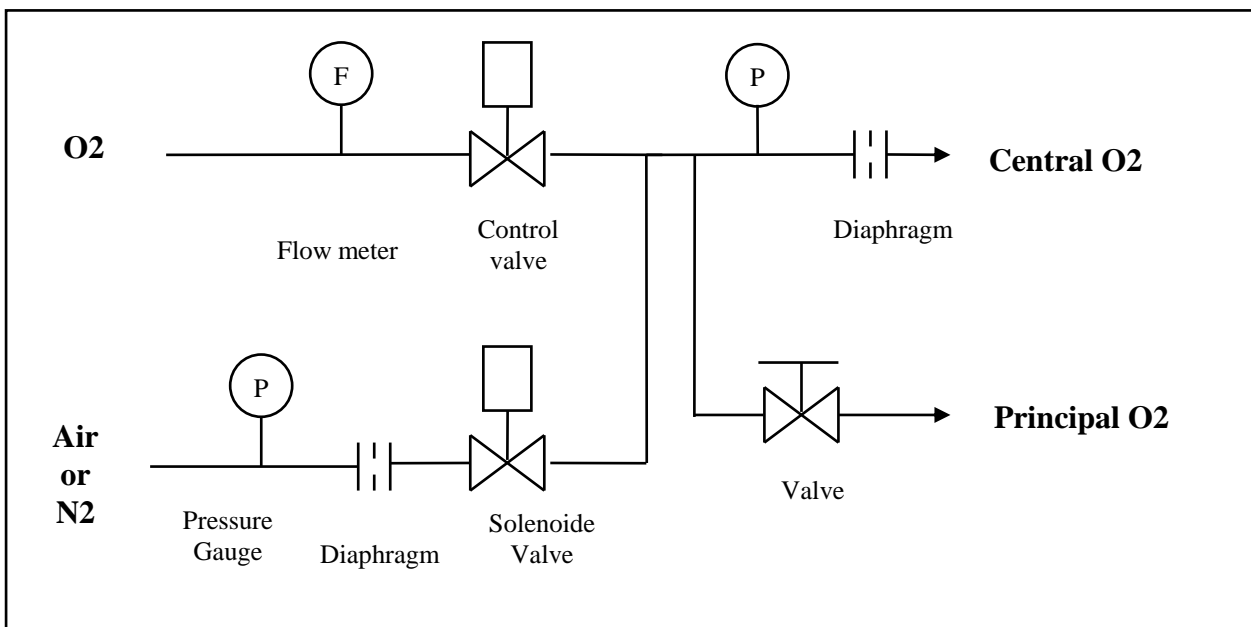

Figure 5

3.6 - REPARTITION OF THE OXYGEN IN THE BURNER

The Glass Melting Burner-VM has three supplies:

- The central oxygen supply (1).
- The fuel gas supply (2).
- The principal oxygen supply (3).

The quantity of oxygen going through the central injector of the Glass Melting Burner-VM permits to adjust characteristics of the flame (Figure 6). More oxygen in the center makes a shorter flame.

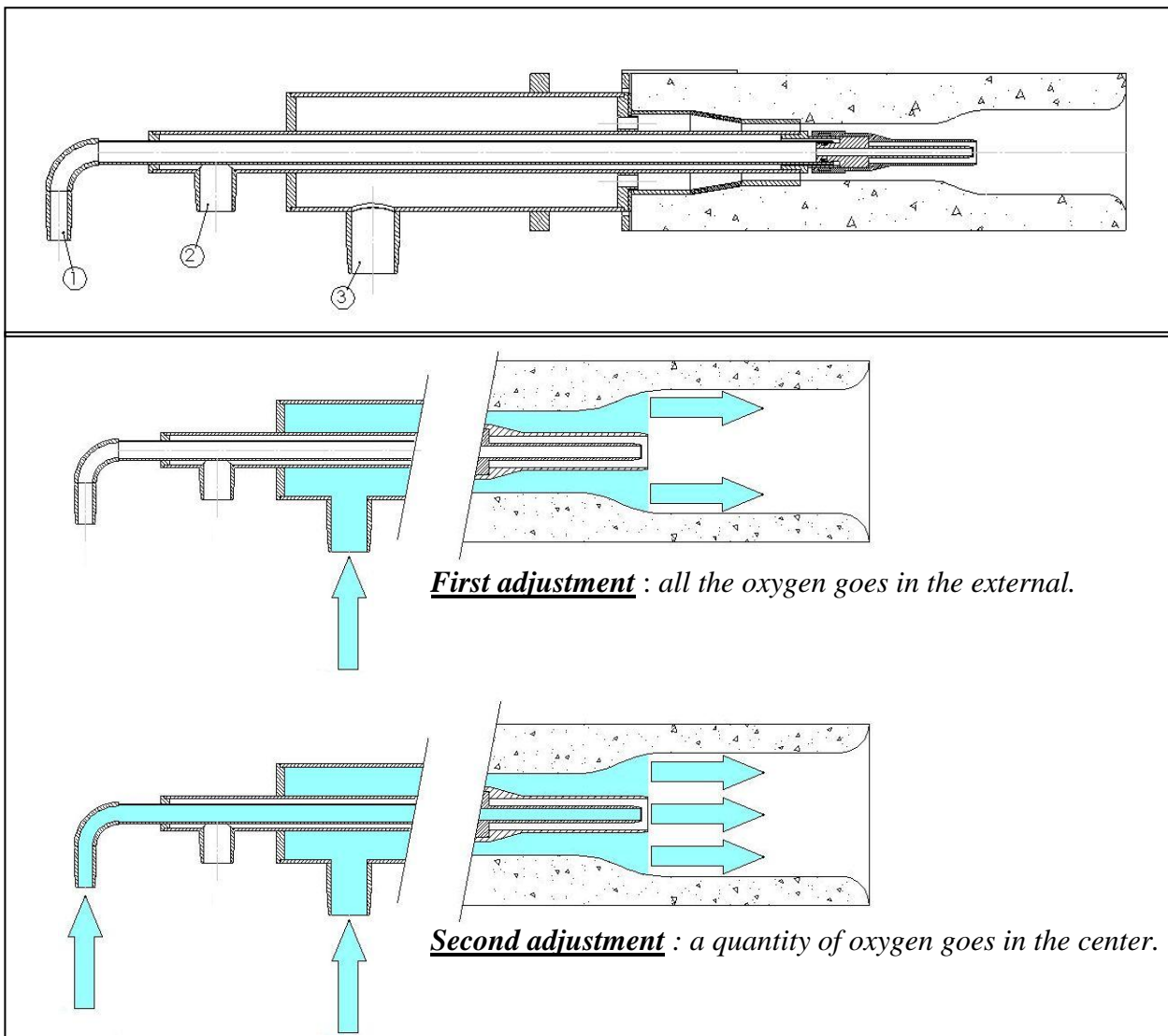

Figure 6

3.7 - INSTALLATION OF THE BURNER ON THE BLOCK

Install the burner on the block just before firing it.

- ◆ Connect the principal oxygen hose to the burner (Ext O₂).
- ◆ Connect the central oxygen hose to the burner (Int O₂).
- ◆ Check that nitrogen or oil free dry cooling air is supplied at the burner.
- ◆ Place the ceramic gasket on the burner body.
- ◆ Check that the inside of the block is not obstructed by foreign materials (fibrous refractory or glass condensates).
- ◆ Place the burner in the block (Figure 7). Place the bracket adapter bolts in the burner body plate slots, and tighten them to compress the ceramic gasket.
- ◆ Connect the fuel gas hose to the burner.
- ◆ To avoid the over heating of the injectors, firing the burner as soon as possible.
- ◆ Cooling air must flow the burner if the burner stops. If not, the burner must be dismantled from the block.

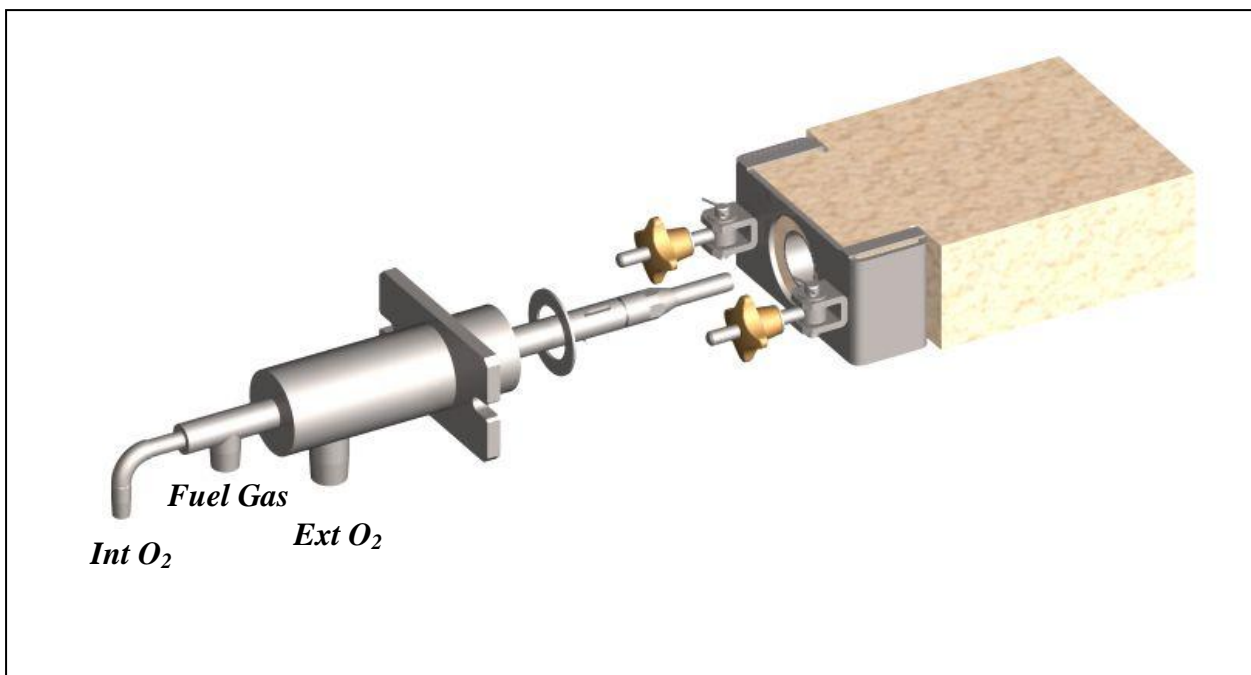

Figure 7

4 - BURNER MAINTENANCE

It may be necessary to remove a burner for regular maintenance inspections, or when the burner will not be used for a long period of time.

4.1- INSPECTION OF THE INJECTORS

- ◆ Turn the burner off: there is immediately a cooling (nitrogen or oil free dry cooling air) supplied in the burner to protect the tips.
- ◆ Disconnect the fuel gas hose.
- ◆ Remove the burner from the refractory block.
- ◆ Check the injectors and the inside of the burner block.
- ◆ **Replace the fuel gas or the oxygen injector if necessary (check that the new injector is free of traces of oil and grease, and clean if necessary).**
- ◆ Re-install the burner.
- ◆ Connect the fuel gas hose.

The burner is operational and can be firing.

During the first month of operation of the burner, inspection of the injectors must be carried out every week. During the second month, the period between inspections can be extended to two weeks. Air Liquide recommends that each injector is inspected every month, and every time a burner is left in the furnace without cooling air.

4.2 - UNMOUNTING THE BURNER

When the burner is not going to be used for extended periods of time, the burner should be removed from the burner block.

- ◆ Turn the burner off, nitrogen or oil free dry cooling air is flowing in the burner.
- ◆ Remove the fuel gas hose.
- ◆ Remove the burner body from the burner block.
- ◆ Remove the principal oxygen hose.
- ◆ Remove the central oxygen hose.
- ◆ Plug the block orifice with alumina wool.
- ◆ Store the burner body and the injectors in a clean area.

A burner that was previously removed may be re-installed by following the same procedure as described in Chapter 3. **Use only new ceramic gaskets for the burner body block tightness.**

The inside of the block has to be inspected and cleaned if necessary.

4.3 - MAINTENANCE

Every time a burner is unmounted, a cleaning of the metallic parts that are in contact with pure oxygen by a specific cleaner product for oil and grease is mandatory.

The " Viton " joint must be inspected every 3 months.

Every year, all these sealing components must be replaced by new ones.

5 - SAFETY WITH OXY-COMBUSTION

Every operator who manipulates the oxy-fuel Glass Melting Burner-VM should be trained on oxygen safety procedures. In particular, operators must be aware of the following safety instructions for oxygen use:

- ◆ **Never use oil or grease for oxygen piping, nor assembling burner parts.**
- ◆ **Do not use organic materials for tightness components.**
- ◆ **Always clean all parts before installing them.**

Failure to respect these instructions may cause ignition in the oxygen circuit, and further propagation along the oxygen piping.

6 - APPENDIX**6.1 REFERENCES****6.11 References for the Glass Melting Burner-VM 20 kW Natural Gas without valve**

References	Description
50 089 - 00 - C	Assembled structure
50 080 - 00 - A	O ₂ injector
50 081 - 00 - A	Natural Gas injector
50 031 - 00 - B	Claw
50 093 - 00 - B	Refractory block
50 032 - 00 - C	Body

6.12 References for the Glass Melting Burner-VM 20 kW Propane without valve

References	Description
50 089 - 00 - C	Assembled structure
50 080 - 00 - A	O ₂ injector
50 082 - 00 - A	Propane injector
50 031 - 00 - B	Claw
50 093 - 00 - B	Refractory block
50 032 - 00 - C	Body

6.13 References for the Glass Melting Burner-VM 50 kW Natural Gas without valve

References	Description
50 091 - 00 - C	Assembled structure
50 083 - 00 - A	O ₂ injector
50 084 - 00 - A	Natural Gas injector
50 031 - 00 - B	Claw
50 034 - 00 - C	Refractory block
50 032 - 00 - C	Body

6.14 References for the Glass Melting Burner-VM 50 kW Propane without valve

References	Description
50 091 - 00 - C	Assembled structure
50 083 - 00 - A	O ₂ injector
50 085 - 00 - A	Propane injector
50 031 - 00 - B	Claw
50 034 - 00 - C	Refractory block
50 032 - 00 - C	Body

6.2 BURNER SPECIFICATIONS

6.21 Burner specifications for the Glass Melting Burner-VM 20 kW

Model	Glass Melting Burner-VM 20 kW Natural Gas	Glass Melting Burner-VM 20 kW Propane
Max - Power	60 kW	60 kW
Nominal - Power	20 kW	20 kW
Min - Power	15 kW	15 kW
Cooling Air Flow	4 Nm ³ /h	4 Nm ³ /h
Central O ₂ inlet	1/4"	1/4"
Principal O ₂ inlet	3/4"	3/4"
Fuel Gas inlet	1/2"	1/2"

6.22 Burner specifications for the Glass Melting Burner-VM 50 kW

Model	Glass Melting Burner-VM 50 kW Natural Gas	Glass Melting Burner-VM 50 kW Propane
Max - Power	120 kW	120 kW
Nominal - Power	50 kW	50 kW
Min - Power	30 kW	30 kW
Cooling Air Flow	5 Nm ³ /h	5 Nm ³ /h
Central O ₂ inlet	1/4"	1/4"
Principal O ₂ inlet	3/4"	3/4"
Fuel Gas inlet	1/2"	1/2"

6.3 DIMENSIONS

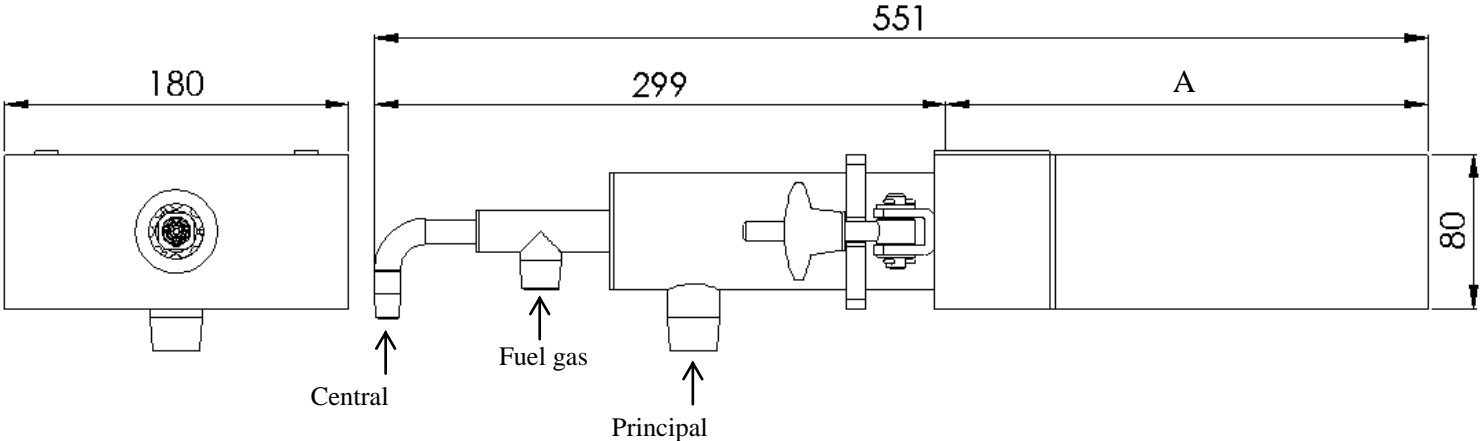

Model	A
Glass Melting Burner-VM 20	227
Glass Melting Burner-VM 50	252